

Combination Stock Reel / Straightener

Durant offers all of its vertical stock reels in combination with motorized stock straighteners. Factory mounted on a heavy duty diamond plate base. Durant presets the proper spacing between the stock reel and straighteners, making certain that all equipment is correctly aligned. The user simply bolts the modular base to the floor and is ready to operate. Spacing is predetermined, eliminating guess work and misalignments that frequently occur.

Contact Durant when purchasing any vertical stock reel and straightener.

For a small additional cost, you now can have a rugged combination space saving machine.

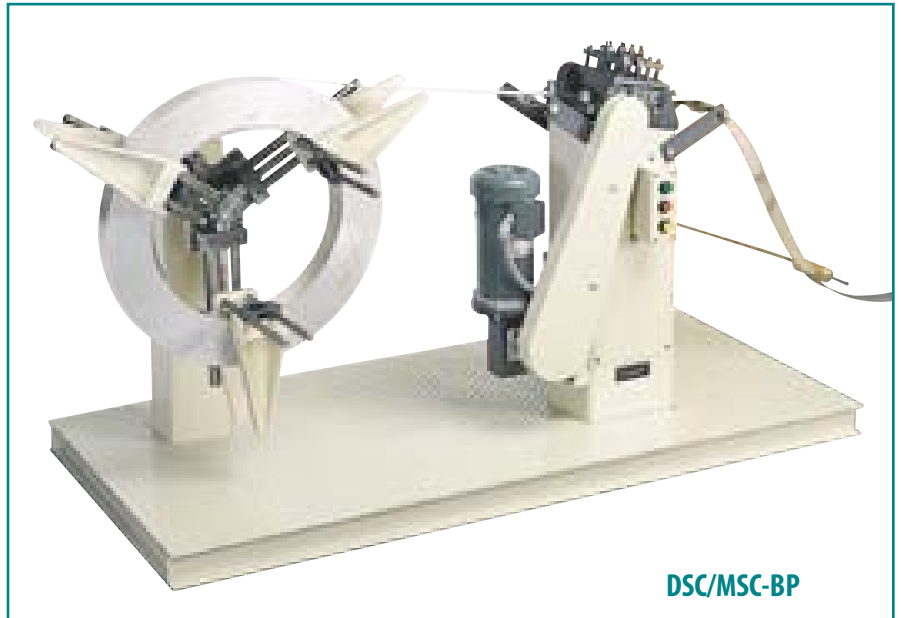

DSC/MSC-BP

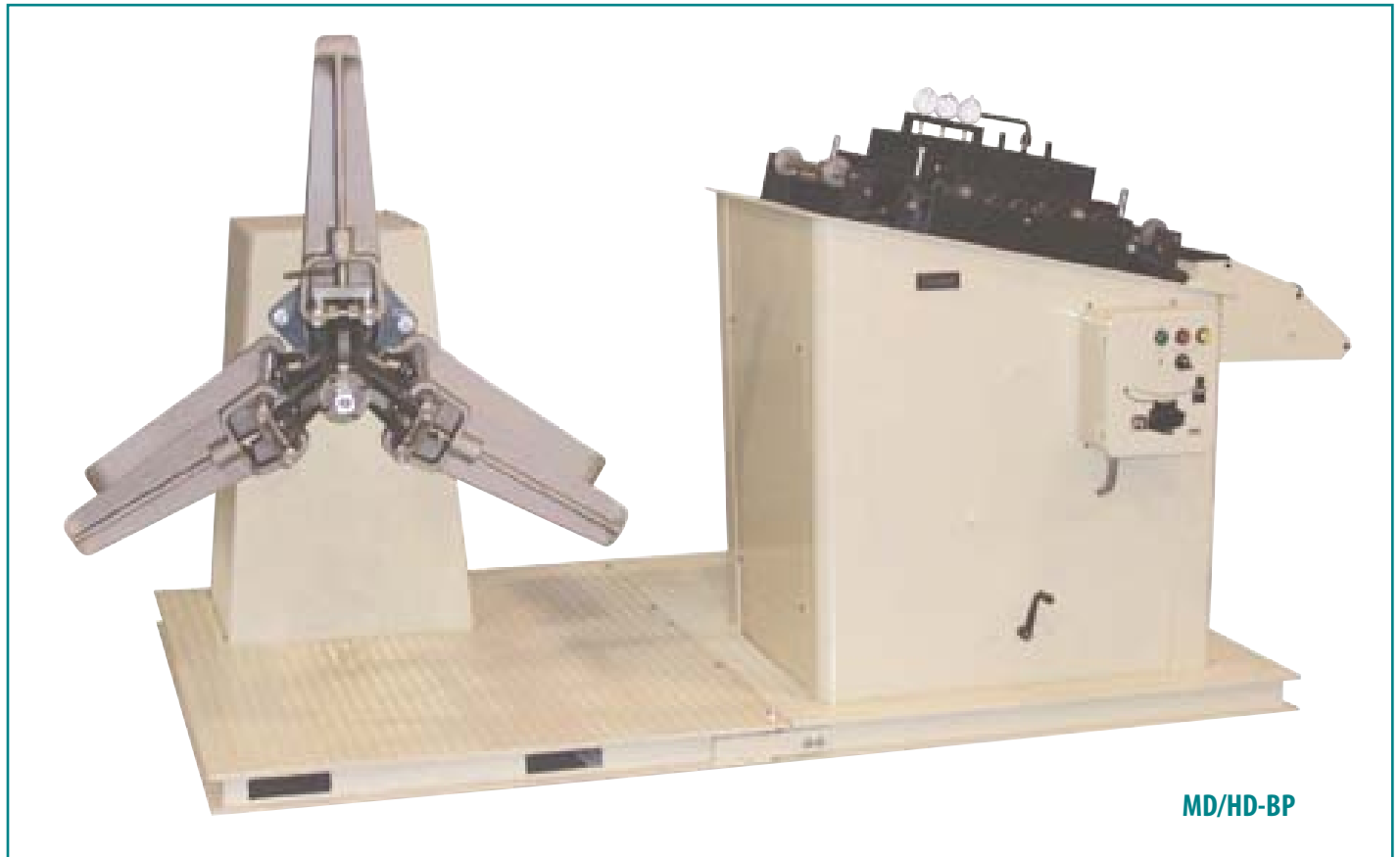

MD/HD-BP

See Pages 31-55 For Additional Information or Call DURANT!

Combination Stock Reel / Straightener

See
Page 50



DSC-1/MSC-27

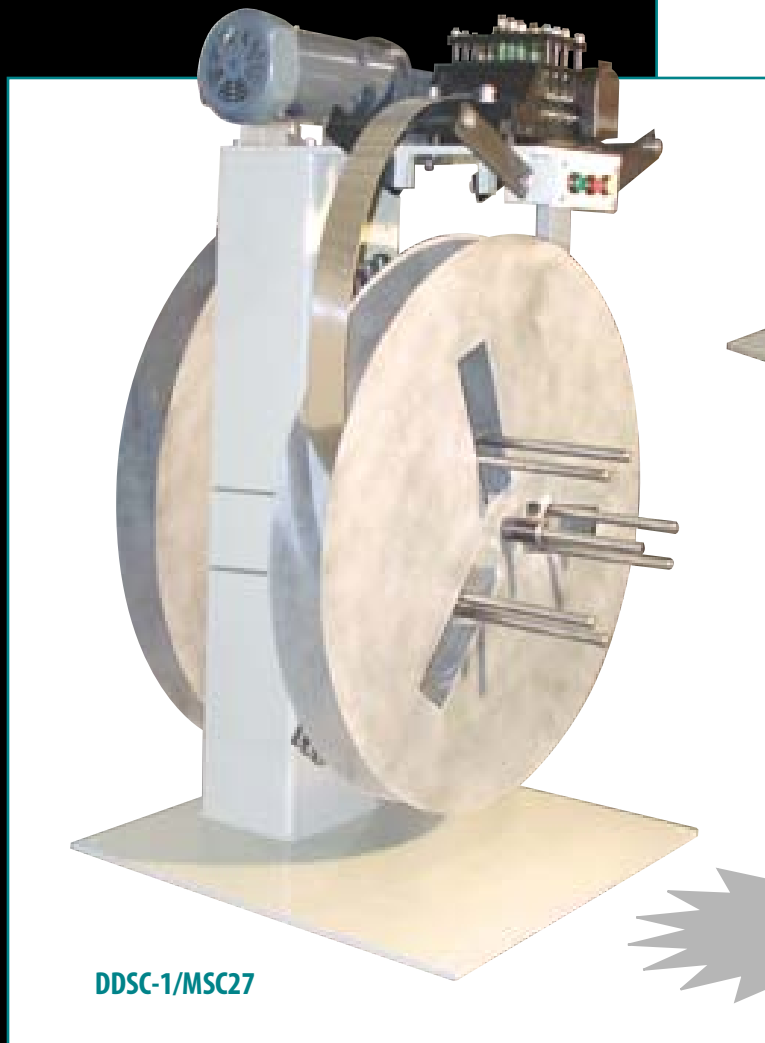

DDSC-1/MSC27

See
Page 51

Adjustable Core Stock Reels / Rewind Reels

Stock Reels With Keeper Arms

Unmotorized Models

Model DSC with Keeper Arms (unmotorized)

Our D Series of Stock Reels are available in both unmotorized and motorized models - All reels are self-centering, heavily constructed, and well balanced. Arms are easily located on heavy rods for narrow and wide coils. Full ball-bearing construction insures long trouble free service at maximum capacity. Heavy duty brakes are available for high speed roll forming and slitting applications.

UNMOTORIZED						
Model	Maximum Width	Maximum OD	Core Diameter	Weight Capacity	Motor	Brake
D50-U	6"	44"	6-24"	50 lbs.	None	Standard
D100-U	6"	44"	6-24"	100 lbs.	None	Standard
D250-U	6"	44"	6-24"	250 lbs.	None	Standard
DSC-0	8"	44"	6-24"	400 lbs.	None	Standard
DSC-1	10"	44"	6-24"	600 lbs.	None	Standard
DSC-2	13"	48"	8-24"	1200 lbs.	None	Standard
DSC-3	18"	48"	8-24"	600 lbs.	None	Standard

Also available with double spindle. See Pages 40-41.

OPTIONS:

- 48" diameter coil discs. • Air or Electrical Brake • 4" I.D. Coils

Motorized Models with Keeper Arms

Model DMSC & VS-DMSC with Keeper Arms

These models offer all the advantages of our unmotorized DSC Models -- self centering, ball bearing construction, and easy to operate arms located on heavy rods for either wide or narrow coils. In addition, the motorization on these three models make it possible to set up for just about any range of coils you're likely to require.

FIXED SPEED					
Model	Maximum Width	Maximum OD	Core Diameter	Weight Capacity	Motor
D50-M	6"	44"	6-24"	50 lbs.	1/4 HP, 110V
D100-M	6"	44"	6-24"	100 lbs.	1/4 HP, 110V
D250-M	6"	44"	6-24"	250 lbs.	1/4 HP, 110V
DMSC-0	8"	44"	6-24"	400 lbs.	1/4 HP, 110V
DMSC-1	10"	44"	6-24"	600 lbs.	1/4 HP, 110V
DMSC-2	13"	48"	8-24"	1200 lbs.	1/4 HP, 110V
DMSC-3	18"	48"	8-24"	600 lbs.	1/4 HP, 110V

VARI SPEED						
Model	Max. Width	Max. OD	Core Diameter	Weight Capacity	Motor	Spindle RPM
VS-D50-M	6"	44"	6-24"	50 lbs.	1/4 HP, 110V	0-25
VS-D100-M	6"	44"	6-24"	100 lbs.	1/4 HP, 110V	0-25
VS-D250-M	6"	44"	6-24"	250 lbs.	1/4 HP, 110V	0-25
VS-DMSC-0	8"	44"	6-24"	400 lbs.	1/4 HP, 110V	0-25
VS-DMSC-1	10"	44"	6-24"	600 lbs.	1/4 HP, 110V	0-25
VS-DMSC-2	13"	48"	8-24"	1200 lbs.	1/4 HP, 110V	0-25
VS-DMSC-3	18"	48"	8-24"	600 lbs.	1/4 HP, 110V	0-25

Also available with double spindle. See Pages 40-41.

- OPTION:** • Rewind Option • 4" I.D. Coils

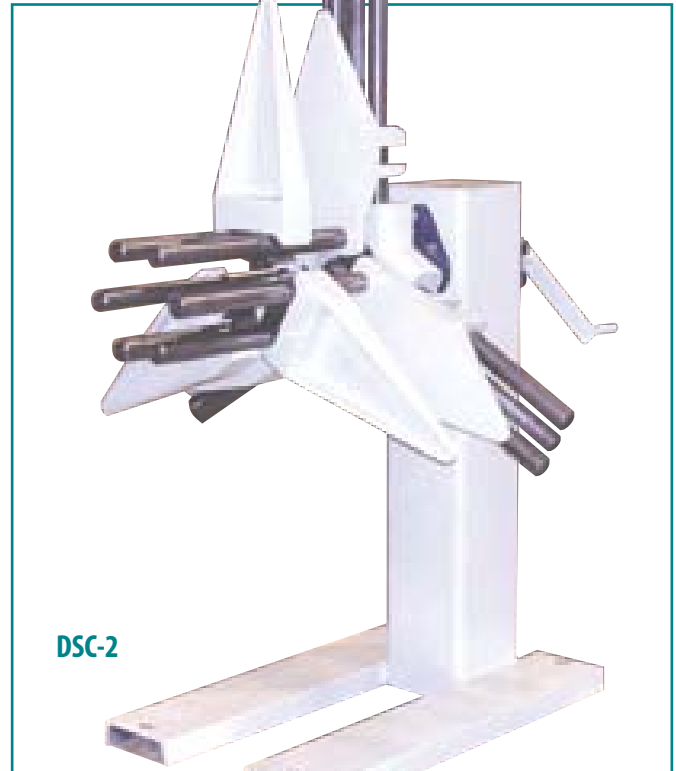

DSC-2



Model D 100-U
with Coil Discs



Adjustable Core Stock Reels / Rewind Reels

Motorized Models with Coil Discs

Model DMSC With Coil Discs (Fixed Speed)

Now you can have the competitive pricing and ease of operation associated with our well accepted stock reels with the added advantage of coil discs. At a rugged 1/8" thick, these coil discs will hold up to long term heavy use. Reels are available in 35" and 48" outside plate diameters. If you do not want to deal with keeper arms, these motorized Durant models are an obvious choice.

FIXED SPEED MOTORIZED					
Model	Max. Width	Max. OD	Core Dia.	Weight Capacity	Motor
D50-M-CD-24	6"	24"	6-24"	50 lbs.	1/4 HP, 110 V
D100-M-CD-35	6"	35"	6-24"	100 lbs.	1/4 HP, 110 V
D250-M-CD-35	6"	35"	6-24"	250 lbs.	1/4 HP, 110 V
DMSC-0-CD-48	8"	48"	6-24"	400 lbs.	1/4 HP, 110 V
DMSC-1-CD-48	10"	48"	6-24"	600 lbs.	1/4 HP, 110 V
DMSC-2-CD-48	13"	48"	8-24"	1200 lbs.	1/4 HP, 110 V
DMSC-3-CD-48	18"	48"	8-24"	600 lbs.	1/4 HP, 110 V

Also available with double spindle. See pages 40-41.

OPTIONS:

- Rewind Option
- 4" I.D. Coils

Need Stock Reels?
Durant Has The Largest Selection In The Metal Stamping Industry!



VS-DMSC-2-CD-48

Model VS-DMSC-CD with Coil Discs (Variable Speed)

Durant's very popular D Series stock reels are now equipped, as a standard item, with coil discs in place of keeper arms. All coil discs are 1/8" thick, and are available in 48" outside diameter plates.

These heavily constructed stock reels, with coil discs and vari-speed dancer loop control, offer total versatility and trouble free performance.

VARI SPEED MOTORIZED					
Model	Max. Width	Max. OD	Core Dia.	Weight Capacity	Motor
VS-D50-M-CD-24	6"	24"	6-24"	50 lbs.	1/4 HP, 110 V
VS-D100-M-CD-35	6"	35"	6-24"	100 lbs.	1/4 HP, 110 V
VS-D250-M-CD-35	6"	35"	6-24"	250 lbs.	1/4 HP, 110 V
VS-DMSC-0-CD-48	8"	48"	6-24"	400 lbs.	1/4 HP, 110 V
VS-DMSC-1-CD-48	10"	48"	6-24"	600 lbs.	1/4 HP, 110 V
VS-DMSC-2-CD-48	13"	48"	8-24"	1200 lbs.	1/4 HP, 110 V
VS-DMSC-3-CD-48	18"	48"	8-24"	600 lbs.	1/4 HP, 110 V

Also available with double spindle. See pages 40-41.

OPTIONS:

- Rewind Option
- 4" I.D. Coils

Adjustable Core Stock Reels / Rewind Reels

When pay out has to pay off in a big way...

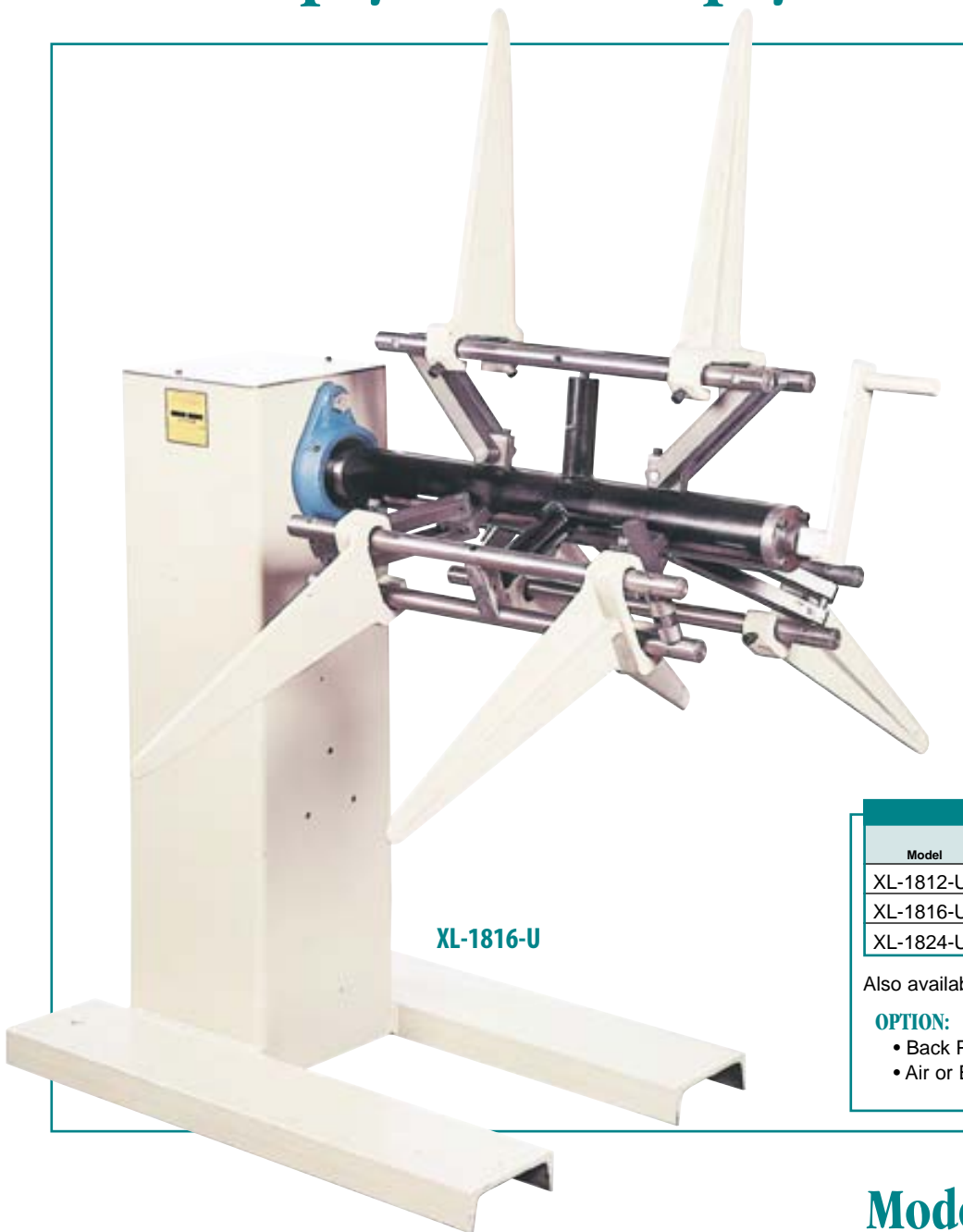

XL-1816-U

Model XL-1800 Unmotorized

When it comes to the 1,800 pound stock reel class, the Durant XL-1800 Series is in a class by itself. Constructed of durable, heavy walled steel tubing throughout, these reels offer 1,800 pound capacity. They are equipped with six rugged coil arms which easily adjust on heavy rods, and a drag brake, which comes standard on all models, eliminating material over travel.

UNMOTORIZED

Model	Max. Width	I.D.	Max. O.D.	Brake	Weight Capacity
XL-1812-U	12"	15-20"	54"	Std.	1800 lbs.
XL-1816-U	16"	15-20"	54"	Std.	1800 lbs.
XL-1824-U	24"	15-20"	54"	Std.	1800 lbs.

Also available with double spindle. See pages 40-41.

OPTION:

- Back Plate 60" O.D. Coil
- Air or Electric Brake

Model XL-1800 Motorized

If you are looking to get long service with minimum maintenance, you are looking for a stock reel with self centering, easy loading, and loop control as standard features. That is exactly what you get with this series of stock reels from Durant. The standard motorization is 220/440 60C 3 phase with a 3/4 HP motor. To make sure there is a free loop of material in front of the feed at all times, these reels are equipped with a special loop control feature.

MOTORIZED

Vari Speed	Model Fixed Speed	Max. Width	I.D.	Max. O.D.	Motor	Weight Capacity
VS-XL-1812-M	XL-1812-M	12"	15-20"	54"	3/4 HP, 220/440 Volt	1800 lbs.
VS-XL-1816-M	XL-1816-M	16"	15-20"	54"	3/4 HP, 220/440 Volt	1800 lbs.
VS-XL-1824-M	XL-1824-M	24"	15-20"	54"	3/4 HP, 220/440 Volt	1800 lbs.

"VS" - Variable Speed DC Drive
Also available with double spindle. See pages 40-41.

OPTION: • Back Plate 60" O.D. Coil



Adjustable Core Stock Reels / Rewind Reels

...Call on Durant.

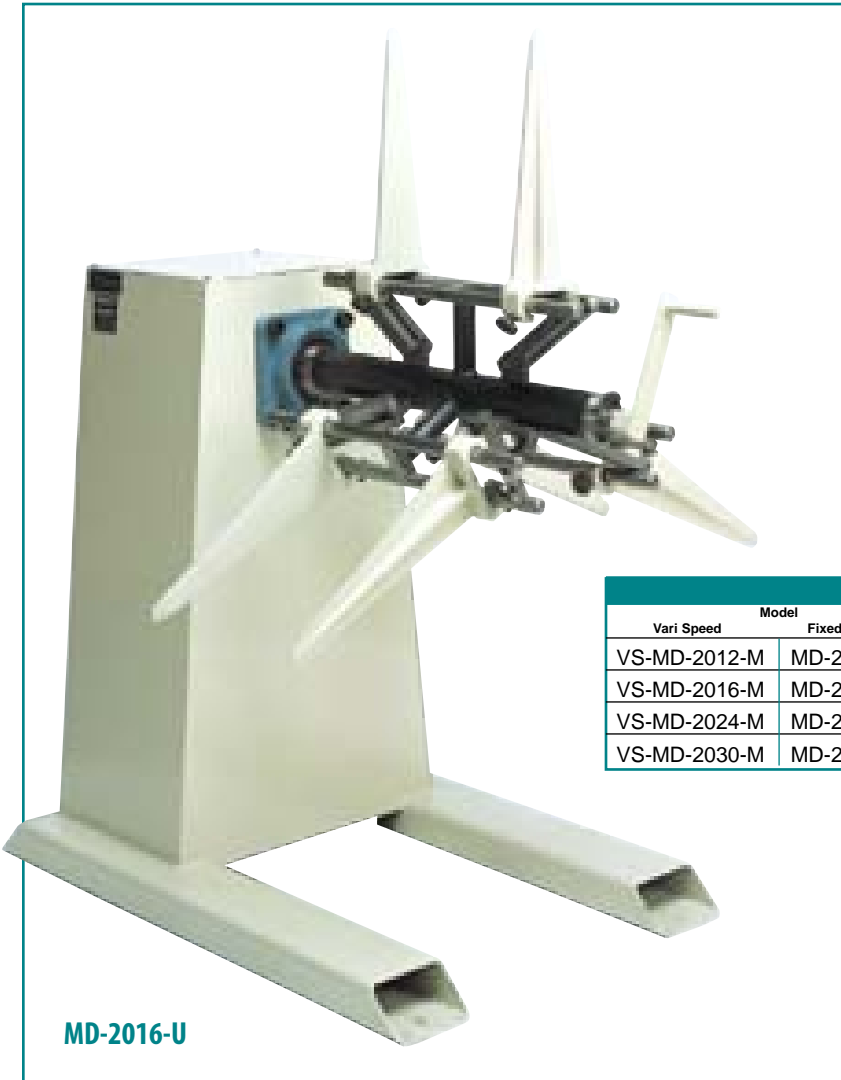

Model MD-2000 Motorized

If you are looking to get long service with minimum maintenance, you are looking for a stock reel with self centering, easy loading, and loop control as standard features. That is exactly what you get with this series of stock reels from Durant. The standard motorization is 220/440 60C 3 phase with a 3/4 HP motor. Combined with a gear reducer it gives you 19 RPM standard spindle speed which provides a feed out of 72 feet per minute. To make sure there is a free loop of material in front of the feed at all times, these reels are equipped with a special loop control feature.

MOTORIZED							
Vari Speed	Model	Fixed Speed	Width	I.D.	Max. O.D.	Motor	Weight Capacity
VS-MD-2012-M	MD-2012-M		12"	15-20"	54"	3/4 HP, 220/440 Volt	2000 lbs.
VS-MD-2016-M	MD-2016-M		16"	15-20"	54"	3/4 HP, 220/440 Volt	2000 lbs.
VS-MD-2024-M	MD-2024-M		24"	15-20"	54"	3/4 HP, 220/440 Volt	2000 lbs.
VS-MD-2030-M	MD-2030-M		30"	15-20"	54"	3/4 HP, 220/440 Volt	2000 lbs.

"VS" - Variable speed DC Drive
Also available with double spindle. See Pages 40-41.

OPTIONS:

- Rewind Option
- Back Plate 60" O.D. Coil

Model MD-2000 Unmotorized

When it comes to the 1,500 to 2,000 pound stock reel class, the Durant MD-2000 Series is in a class by itself. Constructed of durable, heavy walled steel tubing throughout, these reels offer a full 2,000 pound capacity. They are equipped with six rugged cast iron coil arms which easily adjust on heavy rods. A drag brake, which comes standard on all models, eliminates material over travel.

UNMOTORIZED					
Model	Width	I.D.	Max. O.D.	Brake	Weight Capacity
MD-2012-U	12"	15-20"	54"	STD	2000 lbs.
MD-2016-U	16"	15-20"	54"	STD	2000 lbs.
MD-2024-U	24"	15-20"	54"	STD	2000 lbs.
MD-2030-U	30"	15-20"	54"	STD	2000 lbs.

Also available with double spindle. See Pages 40-41.

OPTIONS:

- Back Plate 60" O.D. Coil
- Air or Electric Brake

Need Stock Reels?
Durant Has The Largest Selection In The Metal Stamping Industry!

Adjustable Core Stock Reels / Rewind Reels

When pay out has to pay off in a big way...Call on Durant.

Model MD-250, MD-300, MD-400 Motorized

For power press applications or roll forming, or any one of a number of other demanding heavy duty stock reel applications, the Durant Model MD is hands down the best unit you can buy. Each is built with heavy duty bearing, quick-clamping arms, and a fabricated steel base. To perfectly balance coils at all times, the spindle is engineered to constantly self-centralize. Twelve motorized models are available.

MOTORIZED						
Variable Speed	Fixed Speed	Max. Width	I.D.	Max. O.D.	Motor	Wt. Capacity
VS-MD-251-M	MD-251-M	16"	15-20"	54"-60"	1 1/2 HP	2500 lbs.
VS-MD-252-M	MD-252-M	24"	15-20"	54"-60"	1 1/2 HP	2500 lbs.
VS-MD-253-M	MD-253-M	32"	15-20"	54"-60"	1 1/2 HP	2500 lbs.
VS-MD-254-M	MD-254-M	36"	15-20"	54"-60"	1 1/2 HP	2500 lbs.
VS-MD-301-M	MD-301-M	16"	15-20"	54"-60"	2 HP	3000 lbs.
VS-MD-302-M	MD-302-M	24"	15-20"	54"-60"	2 HP	3000 lbs.
VS-MD-303-M	MD-303-M	32"	15-20"	54"-60"	2 HP	3000 lbs.
VS-MD-304-M	MD-304-M	36"	15-20"	54"-60"	2 HP	3000 lbs.
VS-MD-401-M	MD-401-M	16"	15-20"	54"-60"	2 HP	4000 lbs.
VS-MD-402-M	MD-402-M	24"	15-20"	54"-60"	2 HP	4000 lbs.
VS-MD-403-M	MD-403-M	32"	15-20"	54"-60"	2 HP	4000 lbs.
VS-MD-404-M	MD-404-M	36"	15-20"	54"-60"	2 HP	4000 lbs.

"VS" - Variable speed DC Drive
Spindle speed 23 RPM STANDARD
Also available with double spindle. See Pages 40-41.

OPTIONS:

- Rewind Option • Antenna Loop Control • No Touch Loop Control
- "VS" Variable Speed DC Drive • Hydraulic Hold Down Arm • Back Plate

Model MD-250, MD-300, MD-400 Unmotorized

A typical metal stamping factory might be able to get along with less. But with pay off reels from Durant, you do not have to, so why take a chance on equipment that just might let you down. There are 12 models available in this series in widths up to 36" and with capacities up to 4,000 lbs. Each is constructed with a heavy steel cabinet and a "built for business" 4" diameter center spindle shaft.

UNMOTORIZED					
Model	Max. Width	I.D.	Max. O.D.	Brake	Wt. Capacity
MD-251-U	16"	15-20"	54"-60"	STD	2500 lbs.
MD-252-U	24"	15-20"	54"-60"	STD	2500 lbs.
MD-253-U	32"	15-20"	54"-60"	STD	2500 lbs.
MD-254-U	36"	15-20"	54"-60"	STD	2500 lbs.
MD-301-U	16"	15-20"	54"-60"	STD	3000 lbs.
MD-302-U	24"	15-20"	54"-60"	STD	3000 lbs.
MD-303-U	32"	15-20"	54"-60"	STD	3000 lbs.
MD-304-U	36"	15-20"	54"-60"	STD	3000 lbs.
MD-401-U	16"	15-20"	54"-60"	STD	4000 lbs.
MD-402-U	24"	15-20"	54"-60"	STD	4000 lbs.
MD-403-U	32"	15-20"	54"-60"	STD	4000 lbs.
MD-404-U	36"	15-20"	54"-60"	STD	4000 lbs.

Also available with double spindle. See Pages 40-41.

OPTIONS:

- "VS" Variable Speed DC Drive
- Hydraulic Hold Down Arm • Back Plate



Heavy Duty Stock Reels / Rewind Reels

MD-500, MD-600 Unmotorized

Running off a 6,000 pound coil requires a stock reel with a big enough pay off to take it in stride. That means the MD-500 or MD-600 which are now available in ten models. Each is equipped with a heavy constructed steel cabinet, six rugged quick adjust keeper arms, a drag brake, and oversized self aligning bearings.

UNMOTORIZED					
Model	Max. Width	I.D.	Max. O.D.	Brake	Wt. Capacity
MD-501-U	12"	15-20"	54-60"	STD	5000 lbs.
MD-502-U	24"	15-20"	54-60"	STD	5000 lbs.
MD-503-U	32"	15-20"	54-60"	STD	5000 lbs.
MD-504-U	36"	15-20"	54-60"	STD	5000 lbs.
MD-505-U	48"	15-20"	54-60"	STD	3000 lbs.
MD-601-U	12"	15-20"	54-60"	STD	6000 lbs.
MD-602-U	24"	15-20"	54-60"	STD	6000 lbs.
MD-603-U	32"	15-20"	54-60"	STD	6000 lbs.
MD-604-U	36"	15-20"	54-60"	STD	6000 lbs.
MD-605-U	48"	15-20"	54-60"	STD	3000 lbs.

OPTION:

- Air Brake
- Hydraulic Hold Down Arm
- Back Plate



MD-602-U



MD-603-M
with BACK PLATE

MD-500, MD-600 Motorized

On these heavy duty stock reels, all the options you need come standard. The package includes an electric brake, loop control, jog switch, time delay switch, and reversing switch. The 3 phase motor provides 3 HP 220/440/V, 60C. Up and running it will give you a spindle speed of 23 RPM. Each model is equipped with a heavy constructed steel cabinet, six rugged quick adjust keeper arms and oversized self aligning bearings.

MOTORIZED					
Vari Speed	Fixed Speed	Max. Width	I.D.	Max. O.D.	Wt. Capacity
VS-MD-501-M	MD-501-M	12"	15-20"	54-60"	5000 lbs.
VS-MD-502-M	MD-502-M	24"	15-20"	54-60"	5000 lbs.
VS-MD-503-M	MD-503-M	32"	15-20"	54-60"	5000 lbs.
VS-MD-504-M	MD-504-M	36"	15-20"	54-60"	5000 lbs.
VS-MD-505-M	MD-505-M	48"	15-20"	54-60"	3000 lbs.
VS-MD-601-M	MD-601-M	12"	15-20"	54-60"	6000 lbs.
VS-MD-602-M	MD-602-M	24"	15-20"	54-60"	6000 lbs.
VS-MD-603-M	MD-603-M	32"	15-20"	54-60"	6000 lbs.
VS-MD-604-M	MD-604-M	36"	15-20"	54-60"	6000 lbs.
VS-MD-605-M	MD-605-M	48"	15-20"	54-60"	3000 lbs.

OPTION:

- "VS" Variable Speed DC Drive
- Hydraulic Hold Down Arm
- Back Plate

Model MD-603-M Stock Reel with Back Plate and Coil I.D. Segments. These Optional features are available for all Durant Stock Reels.

Heavy Duty Stock Reels

Heavy Duty Uncoiling . . .Call On Durant!

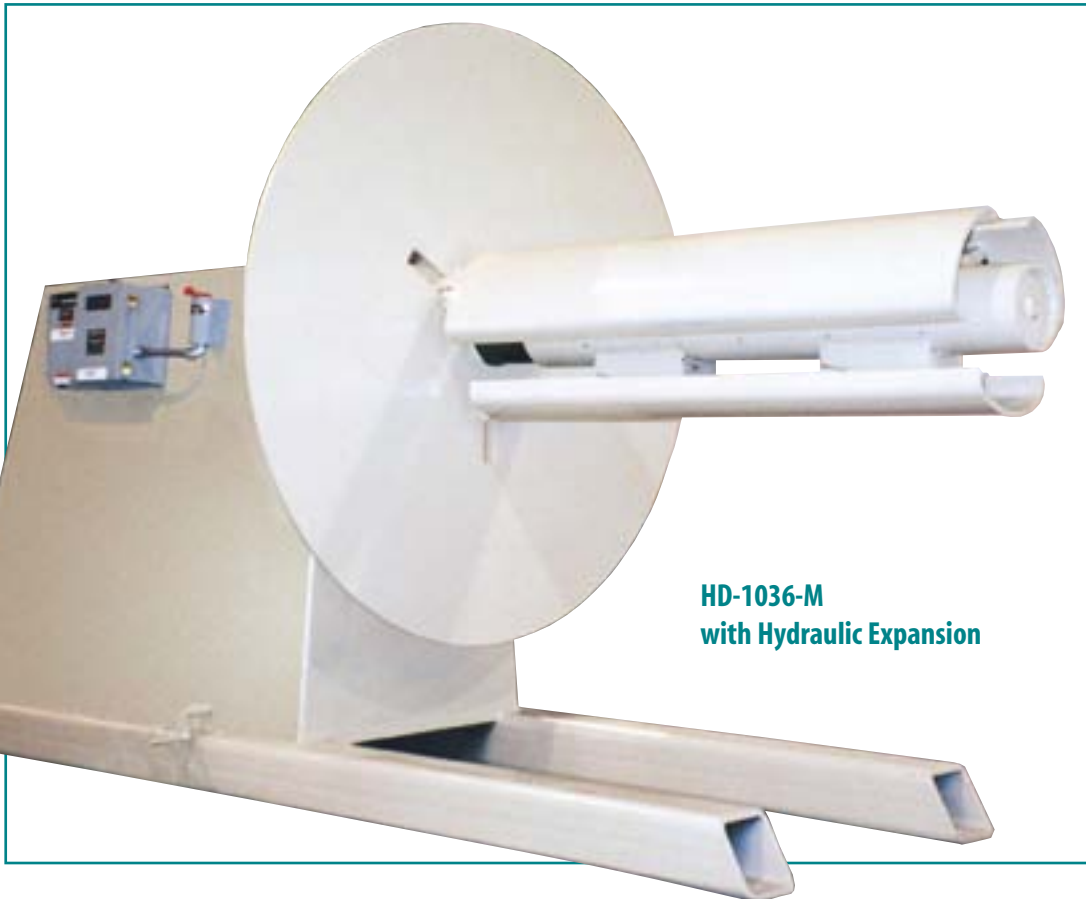

**HD-1036-M
with Hydraulic Expansion**

Durant HD Series Stock Reels

Durant HD Series Stock Reels are available in both non-powered and powered models. Non-powered reels have an air brake which can be adjusted. All powered reels have variable speed drive. All reels contain the finest of materials with the utmost in simplicity. All rotating parts are mounted on heavy duty bearings for maximum efficiency with a minimum cost of operation. An important feature of all Durant HD reels is the use of wedges for expanding the arbor. Wedge type expansion insures smooth and easy loading whether the operator expands the mandrel mechanically or hydraulically.

UNMOTORIZED					
Model	Max. Width	I.D.	Max. O.D.	Brake	Wt. Capacity
HD 624-U	24"	15 1/2 - 20	60"	STD	6000 lbs.
HD 630-U	30"	15 1/2 - 20	60"	STD	6000 lbs.
HD 636-U	36"	15 1/2 - 20	60"	STD	6000 lbs.
HD 648-U	48"	15 1/2 - 20	60"	STD	6000 lbs.
HD 824-U	24"	15 1/2 - 20	60"	STD	8000 lbs.
HD 830-U	30"	15 1/2 - 20	60"	STD	8000 lbs.
HD 836-U	36"	15 1/2 - 20	60"	STD	8000 lbs.
HD 848-U	48"	15 1/2 - 20	60"	STD	8000 lbs.
HD 860-U	60"	15 1/2 - 20	60"	STD	8000 lbs.
HD 1024-U	24"	15 1/2 - 20	60"	STD	10,000 lbs.
HD 1030-U	30"	15 1/2 - 20	60"	STD	10,000 lbs.
HD 1036-U	36"	15 1/2 - 20	60"	STD	10,000 lbs.
HD 1048-U	48"	15 1/2 - 20	60"	STD	10,000 lbs.
HD 1060-U	60"	15 1/2 - 20	60"	STD	10,000 lbs.
HD 1224-U	24"	18-23"	60"	STD	12,000 lbs.
HD 1230-U	30"	18-23"	60"	STD	12,000 lbs.
HD 1236-U	36"	18-23"	60"	STD	12,000 lbs.
HD 1248-U	48"	18-23"	60"	STD	12,000 lbs.
HD 1260-U	60"	18-23"	60"	STD	12,000 lbs.
HD 1524-U	24"	18-23"	60"	STD	15,000 lbs.
HD 1530-U	30"	18-23"	60"	STD	15,000 lbs.
HD 1536-U	36"	18-23"	60"	STD	15,000 lbs.
HD 1548-U	48"	18-23"	60"	STD	15,000 lbs.
HD 1560-U	60"	18-23"	60"	STD	15,000 lbs.

NOTE: Manual Expansion Standard HD 600-1200.
Hydraulic Expansion Option HD 600-1200.
Hydraulic Expansion Standard HD 1500.

Standard Equipment: Air Brake

MOTORIZED					
Model	Max. Width	I.D.	Max. O.D.	Motor	Wt. Capacity
HD 624-M	24"	15 1/2 - 20	60"	3 HP	6000 lbs.
HD 630-M	30"	15 1/2 - 20	60"	3 HP	6000 lbs.
HD 636-M	36"	15 1/2 - 20	60"	3 HP	6000 lbs.
HD 648-M	48"	15 1/2 - 20	60"	3 HP	6000 lbs.
HD 824-M	24"	15 1/2 - 20	60"	5 HP	8000 lbs.
HD 830-M	30"	15 1/2 - 20	60"	5 HP	8000 lbs.
HD 836-M	36"	15 1/2 - 20	60"	5 HP	8000 lbs.
HD 848-M	48"	15 1/2 - 20	60"	5 HP	8000 lbs.
HD 860-M	60"	15 1/2 - 20	60"	5 HP	8000 lbs.
HD 1024-M	24"	15 1/2 - 20	60"	5 HP	10,000 lbs.
HD 1030-M	30"	15 1/2 - 20	60"	5 HP	10,000 lbs.
HD 1036-M	36"	15 1/2 - 20	60"	5 HP	10,000 lbs.
HD 1048-M	48"	15 1/2 - 20	60"	5 HP	10,000 lbs.
HD 1060-M	60"	15 1/2 - 20	60"	5 HP	10,000 lbs.
HD 1224-M	24"	18-23"	60"	5 HP	12,000 lbs.
HD 1230-M	30"	18-23"	60"	5 HP	12,000 lbs.
HD 1236-M	36"	18-23"	60"	5 HP	12,000 lbs.
HD 1248-M	48"	18-23"	60"	5 HP	12,000 lbs.
HD 1260-M	60"	18-23"	60"	5 HP	12,000 lbs.
HD 1524-M	24"	18-23"	60"	5 HP	15,000 lbs.
HD 1530-M	30"	18-23"	60"	5 HP	15,000 lbs.
HD 1536-M	36"	18-23"	60"	5 HP	15,000 lbs.
HD 1548-M	48"	18-23"	60"	5 HP	15,000 lbs.
HD 1560-M	60"	18-23"	60"	5 HP	15,000 lbs.

NOTE: Manual Expansion Standard HD 600-1200. Hydraulic Expansion Option HD 600-1200.

Hydraulic Expansion Standard HD 1500.

OPTION: Hydraulic Hold Down Arm.



Heavy Duty Stock Reels

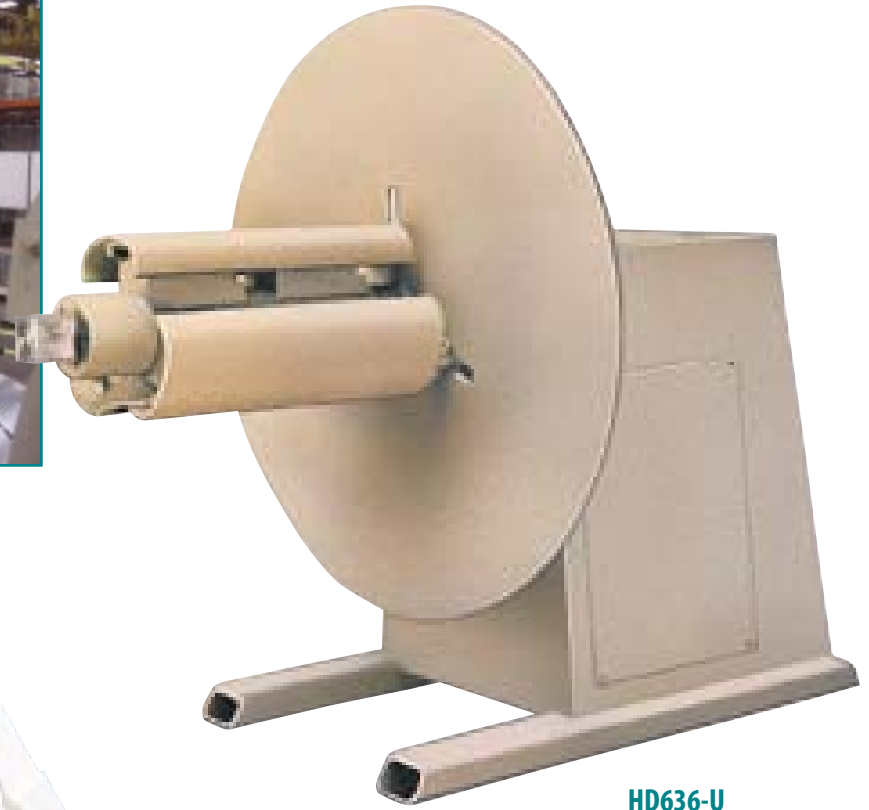

HD636-U



HD 1030-M
with hold down arm



Double Stock Reels

Increase Factory Productivity . . .

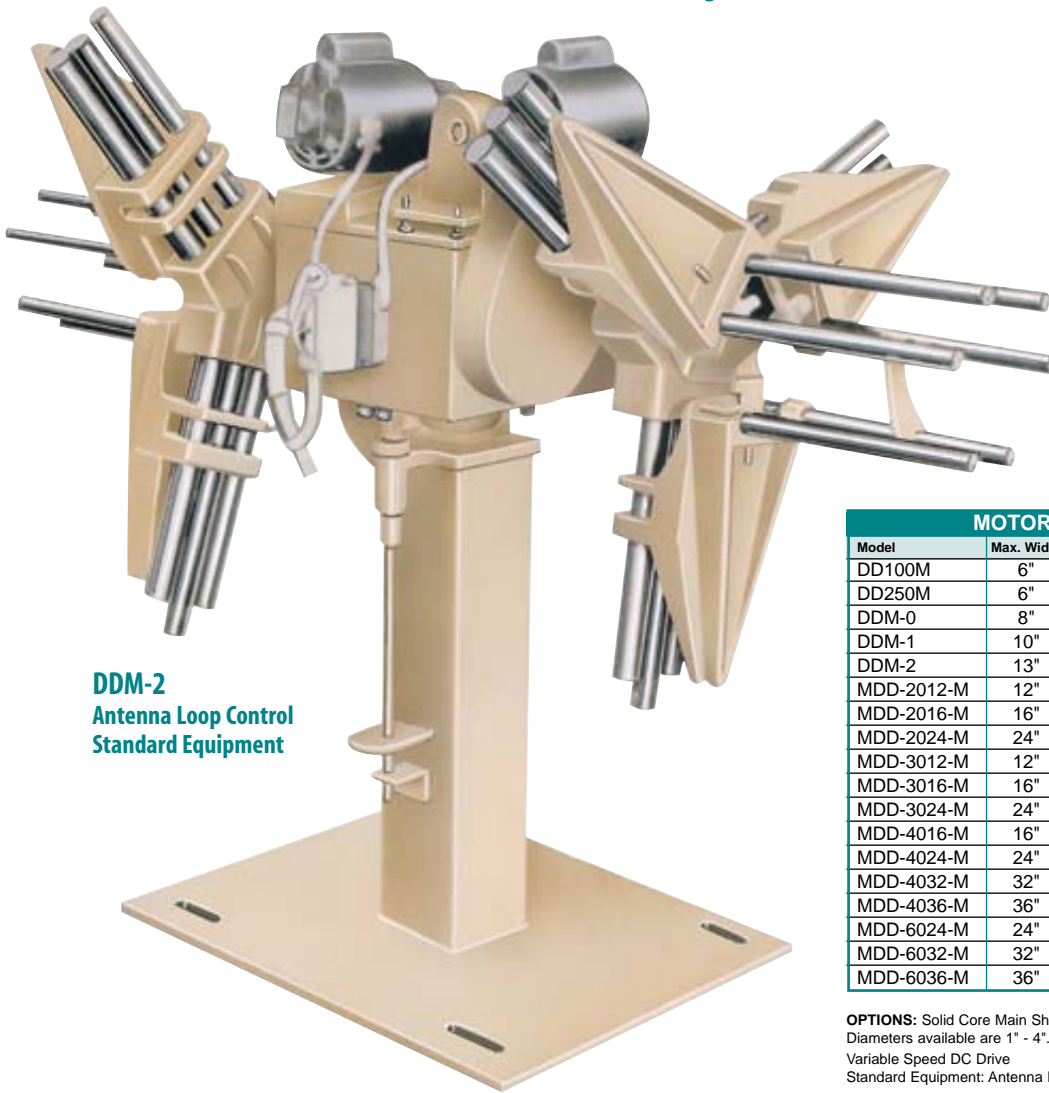

DDM-2
Antenna Loop Control
Standard Equipment

MOTORIZED ADJUSTABLE CORE

Model	Max. Width	I.D.	Max. O.D.	Motor	Wt. Capacity
DD100M	6"	6-24"	44"	1/4 HP	100 lbs.
DD250M	6"	6-24"	44"	1/4 HP	250 lbs.
DDM-0	8"	6-24"	44"	1/4 HP	400 lbs.
DDM-1	10"	6-24"	44"	1/4 HP	600 lbs.
DDM-2	13"	8-24"	48"	1/4 HP	1,200 lbs.
MDD-2012-M	12"	15-20"	48"	1 HP	2,000 lbs.
MDD-2016-M	16"	15-20"	48"	1 HP	2,000 lbs.
MDD-2024-M	24"	15-20"	48"	1 HP	2,000 lbs.
MDD-3012-M	12"	15-20"	54"	1.5 HP	3,000 lbs.
MDD-3016-M	16"	15-20"	54"	1.5 HP	3,000 lbs.
MDD-3024-M	24"	15-20"	54"	1.5 HP	3,000 lbs.
MDD-4016-M	16"	15-20"	54"	2 HP	4,000 lbs.
MDD-4024-M	24"	15-20"	54"	2 HP	4,000 lbs.
MDD-4032-M	32"	15-20"	54"	2 HP	4,000 lbs.
MDD-4036-M	36"	15-20"	54"	2 HP	4,000 lbs.
MDD-6024-M	24"	15-20"	54"	3 HP	6,000 lbs.
MDD-6032-M	32"	15-20"	54"	3 HP	6,000 lbs.
MDD-6036-M	36"	15-20"	54"	3 HP	6,000 lbs.

OPTIONS: Solid Core Main Shaft with Coil Disc.
Diameters available are 1" - 4". Customer to Specify.
Variable Speed DC Drive
Standard Equipment: Antenna Loop Control

UNMOTORIZED ADJUSTABLE CORE

Model	Max. Width	I.D.	Max. O.D.	Brake	Wt. Capacity
DD100U	6"	6-24"	44"	STD.	100 lbs.
DD250U	6"	6-24"	44"	STD.	250 lbs.
DDSC-0	8"	6-24"	44"	STD.	400 lbs.
DDSC-1	10"	6-24"	44"	STD.	600 lbs.
DDSC-2	13"	8-24"	48"	STD.	1,200 lbs.
MDD-2012-U	12"	15-20"	48"	STD.	2,000 lbs.
MDD-2016-U	16"	15-20"	48"	STD.	2,000 lbs.
MDD-2024-U	24"	15-20"	48"	STD.	2,000 lbs.
MDD-3012-U	12"	15-20"	54"	STD.	3,000 lbs.
MDD-3016-U	16"	15-20"	54"	STD.	3,000 lbs.
MDD-3024-U	24"	15-20"	54"	STD.	3,000 lbs.
MDD-4016-U	16"	15-20"	54"	STD.	4,000 lbs.
MDD-4024-U	24"	15-20"	54"	STD.	4,000 lbs.
MDD-4032-U	32"	15-20"	54"	STD.	4,000 lbs.
MDD-4036-U	36"	15-20"	54"	STD.	4,000 lbs.
MDD-6024-U	24"	15-20"	54"	STD.	6,000 lbs.
MDD-6032-U	32"	15-20"	54"	STD.	6,000 lbs.
MDD-6036-U	36"	15-20"	54"	STD.	6,000 lbs.

OPTIONS: Solid Core Main Shaft with Coil Disc.
Diameters available are 1" - 4". Customer to Specify.

Double Stock Reels

All models of Durant stock reels are available in double spindle versions. When one side of the reel is operating, the other side can be loaded. A foot release keeps the reel in position. It can be turned 180 degrees when fully loaded with foot pedal.

Many models are available with either coil keeper arms or coil discs. Coil discs are recommended for thin delicate materials.

Increase your factory productivity! Consider double stock reels with fixed spindle shafts for material on spools or adjustable expanding spindles for bulk coils. Durant manufactures all models in both unmotORIZED "pull off" or motorized versions.

IMPORTANT NOTE: Either solid core or adjustable expanding core available. Call Durant!



Double Stock Reels

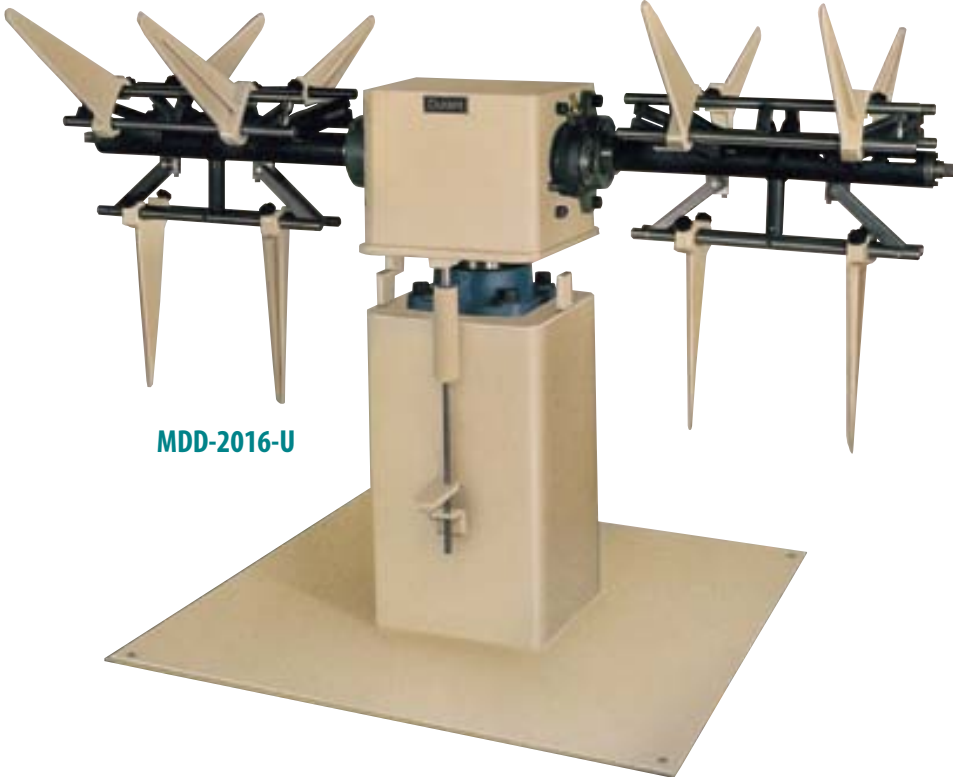

MDD-2016-U



VS-DMD-SS
DMD Double with
rotating side by
side spindles



MDD-4024-M
Antenna Loop Control
and Keeper Arms
Standard Equipment

